



### CFP500 aluminium & technopolymer housing

- ✓ housing made in technopolymer and aluminium
- ✓ weatherproof rating IP66
- ✓ wall, ceiling, pole, corner mounting
- ✓ front and back cover with hook opening system
- ✓ easy fastening and positioning



#### Aluminum and technopolymer housing

**CFP500** housing is made of aluminum and polymer, this makes it strong and light. Suitable for indoor/outdoor installation, thanks to IP66 weatherproof rating, it provides excellent protection against environments. Available there are a wide range of accessories: cameras power supply, ventilation set, anti-tampering set, anticondensing glass, antibreaking glass, etc.

Suitable for most 1/2" 1/3" and 1/4" cameras with fixed focal lenses or compact zoom.

# - DATA SHEET -

## camera housing

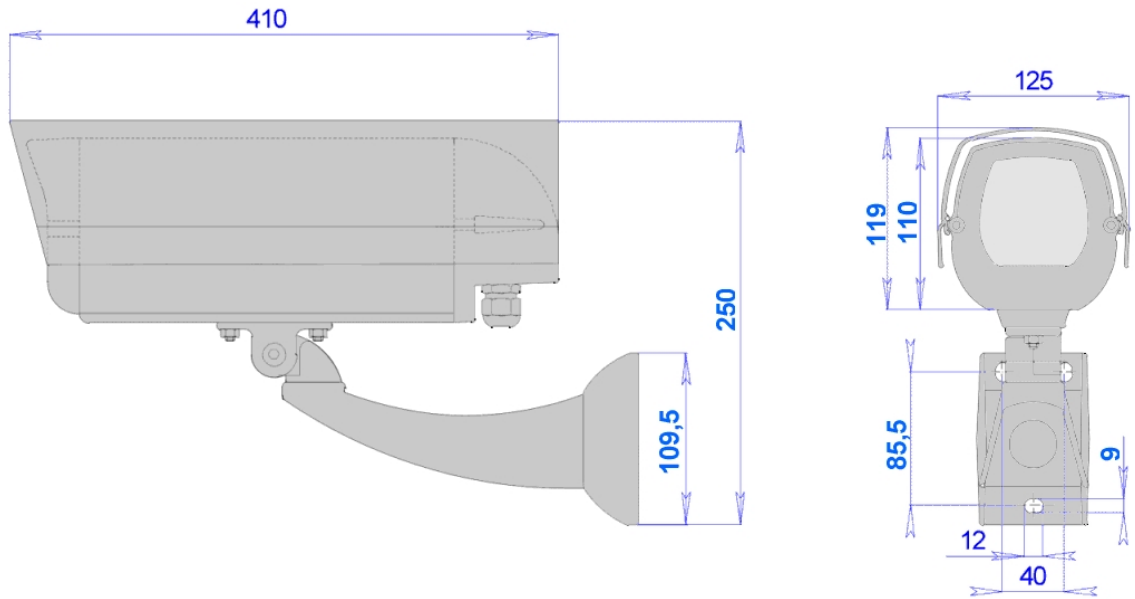

the values are in millimeters

### TECHNICAL DATA

#### GENERAL

- body and sunshield made in aluminium
- painted with polyester powder RAL 7035 (light grey)
- stainless steel bolts and screws
- front and back cover with hook opening system
- heater
- wide range of accessories
- supplied with instruction manual
- according to RoHS compliance

#### ELECTRICAL

- heater 230-110-24-12 Vac  
consumption max. 30W  
t on 15°C t off 22°C +/- 3°C
- ventilation 230Vac, 24Vac, 12Vac  
consumption max. 1W  
t on 37°C t off 27°C +/- 3°C

#### MECHANICAL

- Usable internal space 80x72mm (WxH)  
length 150-240-300mm.
- weatherproof rating IP66
- indoor/outdoor installations
- wall bracket
- operating temperature from -20°C to +50°C
- weight 2,5 Kg. (on version 240mm KIT)

#### RELATED PRODUCTS

- STS500** ceiling bracket
- SP/A** pole adaptor
- SA/A** corner adaptor
- PA1** reinforcing support plate
- PA1/SD** reinforcing support plate in weatherproof box
- PS1** external power supply 230/12Vdc 400mA and 12Vac.
- PS2** external power supply 230/12Vdc 400mA
- PS3** external power supply 230/24Vac 400mA

Specifications are subject to change without notice, weights and dimensions are indicative.