

DATASHEET

ARGO200DH-IR

AINI 316L stainless steel PTZ camera - full HD - with built in IR illuminator

- Sturdy AISI 316L stainless steel construction
- 'Top mount' system
- Dynamic range for reliable capture of details in overexposed situations.
- Max. Resolution 2 Megapixel (1920 x 1080)
- 32x 4.44 ~ 142.6mm optical zoom
- Max. 60 fps @ all resolutions (H.265 / H.264)
- H.265, H.264, MJPEG Codec, multiple streaming
- Day & Night (ICR), WDR (120dB), Defog
- Intelligent Dynamic Noise Reduction.
- **ONVIF® Profile S** certified
- Built-in IR illuminator (wavelength 850nm, distance up to 210m)
- IP66/IP67 weatherproof rating
- Built-in wiper



ARGO200DH-IR is a full HD PTZ camera, made of sturdy AISI 316L stainless steel with electropolishing treatment. The high performance of the 1080p/60fps full HD camera and the sturdy stainless steel construction make this product particularly suitable for marine and/or aggressive environments, where absolute precision and long service life are critical. The infrared illuminator with invisible light to the human eye (850nm) is synchronized with the camera and guarantees optimal vision in any light condition, covering an indicative distance of 210m.

Some of its peculiar features are: the high speed of both horizontal and vertical movements (up to 50°/sec), the maximum precision and the high performance, thanks to the 32x optical zoom. The **ONVIF Profile S** communication protocol ensures a perfect compatibility and integration with any VMS available on the market.

There is a wide range of washer tanks with integrated pump and several delivery head options available, in addition to other accessories: wall bracket, pole adaptor, corner adaptor, etc.

DATASHEET

TECHNICAL DATA

CAMERA

| | |
|---|---|
| Imaging Device | 1/2.8" 2MP CMOS |
| Effective Pixels | 1944(H)x1212(V) |
| Focal Length (Zoom Ratio) | 4.44~142.6mm(32x) motorized varifocal |
| Max. Aperture Ratio | F1.6(Wide) ~ F4.4(Tele) |
| Angular Field of View | H: 61.8°(Wide)~2.19°(Tele), V: 36.2°(Wide)~1.24°(Tele) |
| Streaming | Unicast(20 users) / Multicast Multiple streaming(Up to 10 profiles) |
| Max. Framerate | H.265/H.264 : Max. 60fps/50fps(60Hz/50Hz) MJPEG: Max. 30fps/25fps(60Hz/50Hz) |
| Analytics | Defocus detection, Directional detection, Fog detection, Face detection, Motion detection, Digital auto tracking, Appear/Disappear, Enter/Exit, Loitering, Tampering, Virtual line, Audio detection, Sound classification |
| Application Programming Interface | ONVIF ® Profile S |
| Protocol | IPv4, IPv6, TCP/IP, UDP/IP, RTP(UDP), RTP(TCP), RTCP, RTSP, NTP, HTTP, HTTPS, SSL/TLS, DHCP, FTP, SMTP, ICMP, IGMP, SNMPv1/v2c/v3(MIB-2), ARP, DNS, DDNS, QoS, PIM-SM, UPnP, Bonjour, LLDP, SRTP |
| Resolution | 1920x1080, 1280x1024, 1280x960, 1280x720, 1024x768, 800x600, 800x448, 720x576, 720x480, 640x480, 640x360, 320x240 |
| Wide Dynamic Range | 120dB |
| Digital Image Stabilization | Support |
| Defog | Support |
| Motion Detection | 8ea, 8point polygonal zones |
| Privacy Masking | 32ea, polygonal zones - Color: Grey/Green/Red/Blue/Black/White - Mosaic |
| Electronic Shutter Speed | Minimum / Maximum / Anti flicker (2~1/12,000sec) |
| Camera Title | Displayed up to 85 characters |
| Day & Night Backlight Compensation Camera Title | Auto(ICR) BLC, HLC, WDR, SDR Displayed up to 85 characters |
| Day & Night | Auto(ICR) |
| Electronic Shutter Speed | Minimum / Maximum / Anti flicker (2~1/12,000sec) |
| Preset | Up to 256 presets |

DATASHEET

MECHANICAL

| | |
|---------------------------------|---|
| Material | AISI 316L stainless steel with electropolishing treatment |
| Horiz. movement (Pan) | 360° (continuous rotation) |
| Vert. movement (Tilt) | 180° (+/- 90°) |
| Electronically adjustable speed | Pan: 0 < 50 °/s Tilt: 0 < 50 °/s |
| Weatherproof rating | IP66/IP67 |
| Cable entry | no.3 M16x1,5 metal cable glands no.1 M25x1,5 metal cable gland |
| Storage temperature/ Humidity | from -5°C to +60°C (from 23°F to +140°F) /20% - 95 % |
| Operating temperature/ Humidity | from -30°C to +60°C (from -22°F to +140°F) / 20% - 80% |
| Consumption | Max. 90W |
| Power | 220/240Vac 50/60Hz - 0,5A 110/120Vac 50/60Hz - 1,1A 24Vac 50/60Hz -5A |
| Weight | 28Kg. |
| Dimensions | <i>see technical drawings</i> |

IR ILLUMINATOR PERFORMANCES CHART

| | |
|---------------------------|----------------|
| 10° of illumination angle | Distance 210 * |
| 30° of illumination angle | Distance 160 * |
| 60° of illumination angle | Distance 90 * |

* typical distance in meters depends of the reflection coefficient of the illuminated scene.

ACCESSORIES

| | |
|--------------|----------------------|
| ST200 | Wall bracket |
| SP/CB | Pole mount adapter |
| SA/CB | Corner mount adapter |

OPTIONAL

| | |
|--------------|---|
| WTP5 | 5lt washer tank with integrated pump, 5m delivery head, power supply: 120-230Vac or 24Vac |
| WTP5 | 5lt washer tank with integrated pump, 11m delivery head, power supply: 120-230Vac or 24Vac |
| WTP5 | 5lt washer tank with integrated pump, 19m delivery head, power supply: 120-230Vac or 24Vac |
| WTP25 | 25lt washer tank with integrated pump, 5m delivery head, power supply: 120-230Vac or 24Vac |
| WTP25 | 25lt washer tank with integrated pump, 11m delivery head, power supply: 120-230Vac or 24Vac |
| WTP25 | 25lt washer tank with integrated pump, 19m delivery head, power supply: 120-230Vac or 24Vac |

DATASHEET

TECHNICAL DRAWINGS

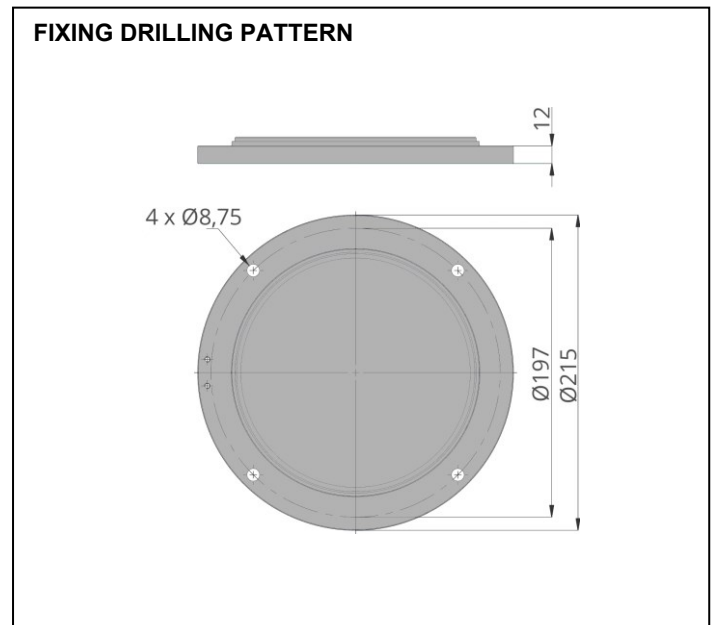
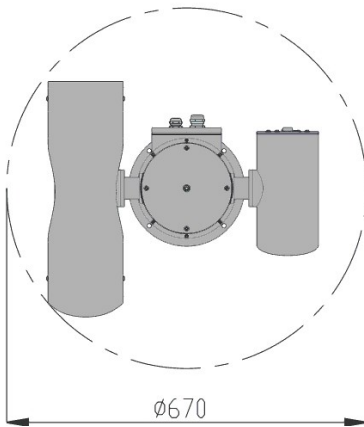
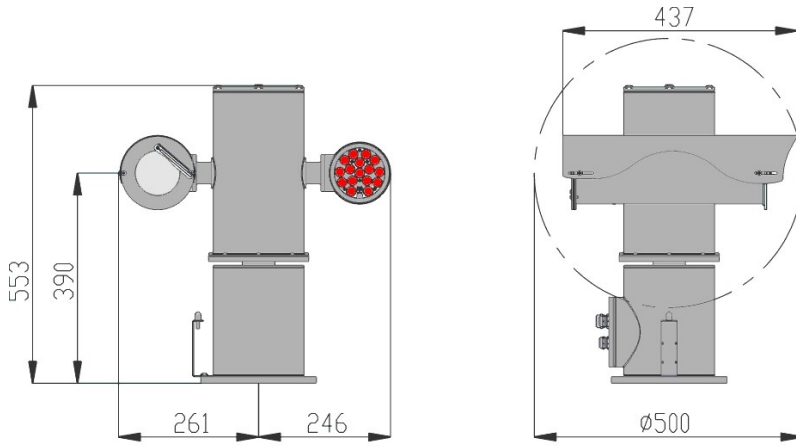

All the dimensions are expressed in millimeters